

## Two way bookshelf speaker

Since 2008 we are designing a range of new DIY models based on the new line of MOREL drive units. This CA 621 is almost the most cost effective 6" model we can think of.

Despite this fact, it presents the honest and well respected, typical "MOREL" sound.

With this model we surprise a lot of people, knowing that this one is only the beginning of a line of speakers only increasing in quality. Yet, don't be mistaken; this CA 621 will bring a lot of building and listening pleasure to a wide range of audiophile builders and listeners.

This model is chosen by Dutch audio Magazine HVT to demonstrate their own made recordings at shows and built it themselves.

If you desire lower and even more precise bass response we recommend to add a CA 911 woofer cabinet, resulting in a full 3-way sealed system.

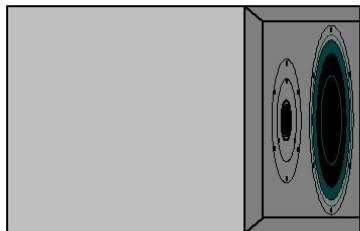

© **ELTIM**<sup>®</sup>  
AUDIO  
CA 621mkIII

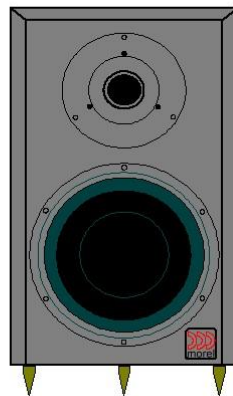
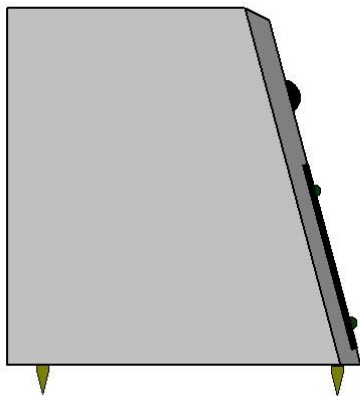

Tweeter: CAT 308  
Woofer: CAW 638  
Freq.range: 60-22.000 Hz  
Efficiency: 85dB  
Nominal load: 150Wrms  
Impedance: 8 ohm  
Crossover: 6/6dB serial  
Crossover point: 2400Hz

Principle: 2-way, sealed

[www.eltim.eu](http://www.eltim.eu)

## Introduction

With the introduction at CES 2008 of a wide new range of MOREL drive units, it finally became possible to design a wide range of modern and compact speakers. The Classic Advanced series are the successors of the well known MW-woofers and MDT-tweeters. We took the challenge and designed this CA 621 (Classic Advanced units, 6" woofer, 2-way system, number 1) as one of our most cost effective true MOREL system using a 6" woofer.

It should become a well known and often built DIY starters model, so price needed to be acceptable low compared to the given quality. Only time will tell if we succeeded.

We only use six panels and a rib inside to strengthen the 22mm MDFT panels. A new 16cm (6") woofer in an alu diecast open basket is assisted by the one of the most cost effective high-end 28mm softdome tweeter available. In order to keep the costs down, we also decided for cost effective crossover components in a simple 6/6dB serial crossover. Due to the few components used, this is not only quit cheap, but has also a very linear phase behaviour which is noticed at

once while listening to this model. The enclosure is calculated at 7,5 liter, resulting in a Q of the ideal 0,707 when stuffed heavily. Using this crossing frequency together with the design and heavy damping, there is an improvement in midrange behavior. With the some smaller cabinet compared to CA620 and the use of a better tweeter, this system could be used together with our CA931 subwoofer cabinet as well.

As said: a nice model to start your DIY hobby.

## The units



For the woofer we use the 6" / 8 ohm model in the "Classic Advanced" range, the **CAW 638**, being the successor of the well known MW-166 and MW-168. With the new diecast aluminium Uniflow basket the unit breaths a lot better as the former models with steel baskets did. In other words: they are able to produce lower frequencies.

The new unit shows even it's anatomy; actually you can see the voicecoil due to the External Voice Coil (EVC) principle, where the magnets are mounted inside the gigantic 75mm aluminium Hexatech coil with hexagonal aluminium wire. The produced heat is moving away from the inner magnet system, with the result that it



hardly ever will compress the sound. Small holes in the former even cause an air flow through the open pole center to increase cooling.



All new MOREL woofers use parameters to meet today's demands and you can build modern slim designs with it. The CAW 638 is calculated for a sealed enclosure of 9,5 liter, using typical damping. We use a heavy damping here, so the cabinet can be about 7,5 liters.

The woofer parameters are choosen very smart, since you can also use it in a 22 liter vented cabinet as well, as we do in our CA 624 and CA 625 models.

The tweeter **CAT 308** is a modified MDT-30s, the most cost effective MOREL tweeter with a rear chamber. Times change and finally it is in the international used  $\varnothing$  104mm. By the way, also the successors of the well known MDT-29 (CAT 298), MDT-32s (CAT328-104), MDT-33 (ET 338-104) and Supreme tweeter (ST 1048) are available in this 104mm size now.

Through the fine silk 28mm handcoated dome you can see the effective damping and the cavity into the rar chamber. This model is equipped with a 28mm Hexatech voicecoil, resulting in a very fast transient response and high load capacity. It is running from 1800 Hz up, without any serious spikes and dips. Due to the new designed faceplate the off-axis response increased compared to the former model MDT-30s.

## The cabinet

With a width of 20cm and a height of 30,6cm this design finds its place in any bookshelf or on a stand, even in smaller living rooms. Also in this design we use the “[golden number](#)”, in the width/height of the baffle, location of the units and shape of the inner rib. This is the reason why the tweeter is mounted higher as you see in most other designs.

Side and top/bottom 22mm MDFT panels are angled 45°, so they fit perfectly without visible sides of MDF. The 22mm MDFT baffle is milled on both sides. At the back we milled it 4/22mm all around. This way the side panels can be positioned quite easy without slipping while the glue is drying. At the front side both units are sunk for a clean look. The edges can be rounded with a fraise or angled by 45° as in our prototype picture and the panels we supply. Be careful with that, because there will only be about 2-3 millimeters left on both sides of the woofer.

With its smaller size and more heavy damping compared to CA620, midrange is clearer. Beside the use in smaller living rooms, you could decide to put it on top of our CA931 subwoofer. In that case you have a full 3-way system (300/2400Hz), using serial 6/6dB crossovers, which sound remarkably fast and open compared to parallel crossovers.

## The crossover

Our designer has the opinion that in combination with MOREL units most simple crossovers bring the best musical results. We mostly just listen and listen and.... while tweaking our designs. Bringing perfect graphs, too often the sound is lifeless, something we don't want.

He used a simple 6/6dB crossover and to increase phase linearity even more, it became a serial crossover. For a correct functioning this type of crossover must “see” a flat impedance load in the woofer and tweeter circuits. To gain this we added some circuits parallel to the woofer (C4/R1) and the tweeter (R5/C6), preventing rise of impedance with frequency. Besides that, a circuit (R4/L2/C5) counteracts the tweeter behaviour around the resonance frequency of 780Hz. Resistors R2/R3 bring down tweeter efficiency to the level of the woofer, being 87dB. The 6/6dB (L1, resp. C1+C2+C3) filter is crossed at 2400Hz today.

This is the basic reason why this crossover is hardly used, since with just “tweaking” you will not

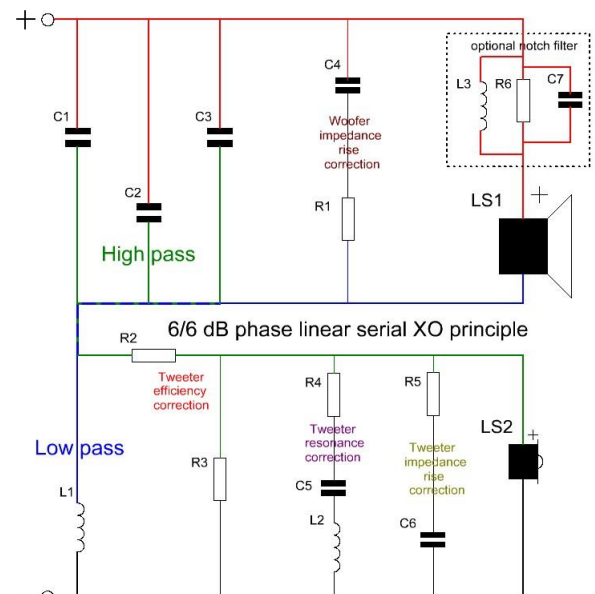

get proper results or spend way too much time in designing. Therefore we made our own software, where we enter all driver parameters and all crossover parts values and try to find a crossing point bringing best results for the purpose. The value of L1 (L140 type) is set first, since we need to use the E12 range, while we can add a small capacitor (C2, ME) to the basic HP capacitor C1 (MCAP400). Even then we cannot get it exactly right, so we alter the compensation



networks a bit to get it exactly right. Practice showed that our software works right after some “bugs” were removed while comparing theory and practice in several of our models. Unlike many

other designs, impedance is nearly flat. Since frequency range of the units is hardly affected by crossover behavior, this graph appears to be quite flat also. As a result most important phase behavior is easily noticed by simply listening to this simple but impressive system.....

### **The damping**

With a sealed enclosure like this, best is to fill it with BAF, etc. The slightly small volume can be compensated by filling it tightly, where midrange becomes more clear as well. Trying different materials is always interesting and makes fun.

*Drawings and components values come with the kits only.*

*Commercial use and/or publishing in any way is prohibited without our consent.*

### **Copyrights and distribution:**

**ELTIM audio BV**

**Eenrummerweg 5**

**NL-9961 PC Mensingeweer**

**T +31 595 491748**

**F +31 595 491946**

**E [info@eltim.eu](mailto:info@eltim.eu)**

**W [www.eltim.eu](http://www.eltim.eu)**

### **Designer:**

**Louis Timmers**

**September 2009**

**Modified:    august 2011 (mkII)  
                  oktober 2013 (mkIII)**

